



GPU 180 kVA · 400Hz

Power	180 kVA
Voltage	115/200Vac
Voltage regulation	± 1%
Power Factor	0,8
Frequency	400Hz
Output 115/200Vac 400Hz	N°2 (90kVA)
Output 28,5Vdc	Option

ENGINES

- **FPT Stage 0** engine: 18F/180TNE @1846rpm
- **FPT Stage IIIA** engine: 18F/180TE @1846rpm
- **Cummins Stage IIIA** engine: 18C/180TE @1846rpm

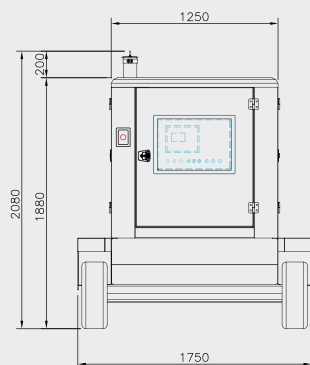
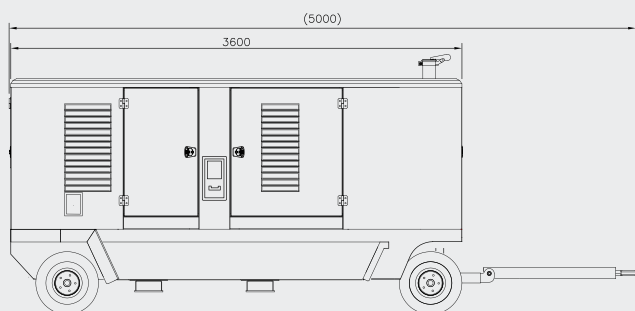

Dimensions are shown in mm



Pictures may not show the actual product due to presence or absence of items



Bertoli provides robust, easy to use and maintain **400Hz diesel ground power units from 60 to 180kVA**. All models feature a user-friendly electronic device for the GPU management through which operators are able to control engine dynamics (low/rated speed, etc.) and energize the desired output(s).

Sound and weatherproof canopies and trailers are designed and manufactured in-house.

Special care is devoted to quality of materials and processing. Product look sober and are an optimal matching of essentiality and maximum functionality, conceived to facilitate end users in operating the machine and get the best out of their technical-mechanical potential.

ENGINE

Brand and Model	FPT - NEF67 (stage 0) DEUTZ - TCD2013 (stage IIIA) FPT - NEF67 (stage IIIA) CUMMINS - QSB 8.3 (stage IIIA)
Type	4 stroke, 6 cylinder, turbo with intercooler
Fuel	Diesel
Speed	2000 or 1846 rpm - electronic governor
Cooling	Water cooling with radiator and blower fan
Starting	Electric starting 24Vdc Batteries 2x12Vdc - 140Ah
Sensors	Oil pressure, Water temperature, fuel level, alternator battery charger

AC OUTPUT

N° of outputs	2 (90kVA each)
Connection	3 phase 4 wire
Voltage	115/200Vac
Frequency	400 Hz
Cables	4x1x70(mm ²)+4x1, twisted, tinned, extra flexible, length 12 meters
Plug	6 poles, standard rubber type

DC OUTPUT (ON REQUEST)

N° of outputs	1
Components	Power transformer + rectification circuit "Line drop compensation" electronic device
Voltage	28,5 Vdc
Power output	800A continuous -1200A 90 sec -2400A max 15 sec
Cables	2x120(mm ²), tinned, extra flexible, length 12 meters
Plug	3 poles, standard rubber type

CONFIGURATION

Chassis	Structural steel base equipped with vibration dampers, lifting facilities fitted.
Trailer*	Max dimensions (mm): L3800 x W1900 x H1900. Max weight (kg): 2800 approx. Strong frame in welded steel sections; two axle trailer with steerable front wheels, fix drawbar. Parking brake automatically operated when the draw bar is in vertical position. Cable storage compartment on both sides of GPU with easy access and appropriate size to cable length. Weatherproof. Anticorrosive treatment (on request). RAL 9010 (other colour on request) Large doors for inspection and maintenance Yellow flashing light on top
Canopy	Size signallers. Adjustable service light. Control panel lighting. Interior lighting for maintenance. Sound level 75 dB(A) @ 7m. Fire extinguisher
Fuel tank	Built in the base frame, about 220 litres capacity with cap
Exhaust silencer	Industrial type

* (Please contact our technical dept. after the order for definitive dimensions and weight)

TECHNICAL DOCUMENTS

Engine	Operation and maintenance technical manual
Alternator	Operation and maintenance technical manual
Control panel	Wiring diagram Printed label fixed on rear side (under the control panel) for a quick start & use of GPU
GPU	Operation and maintenance manual

ALTERNATOR

Power	180 kVA
Cos phi	0,8
Authorized overload	110% of rated load for 1 hour in a 6 hours period 300% of rated load for 20sec
Type	24 or 26 poles, single bearing, brushless, self-excited
Mechanical protection	IP 23
Insulation	Class H
Compliance with	Standard BS 2G 219 – EN2292 ISO 6858 MIL-STD-704F
Voltage regulation	Electronic: ± 1% (With any power factor and speed variations between -5% and +30%)
Waveform distortion (THD)	1,4% at full load
Engine coupling	Direct

CONTROL PANEL

Fitting	On the rear side
Protection	IP 54
Electronic device	Programmable electronic device with backlight digital display. All measures are shown by scrolling pages through built-in buttons. Any alarm latched is displayed with description text.
Measure	Engine: oil pressure, water temperature, fuel level, speed, battery voltage, hour counter, alternator battery charger. 400Hz output: voltage, frequency, current, power kVA-kVAR-kW, Cosphi (measures phase to phase AND phase to neutral). 28Vdc output: voltage, current
Protections: alarms control and automatic shutdown	Pre-configured and editable (through built-in buttons or software) thresholds, each one with its activation delay time: Engine: low oil pressure, high water temperature, low fuel level, overspeed, underspeed, alternator battery charger failure. 400Hz output: over/under voltage, over/under frequency, overload, short circuit, phase sequence 28Vdc output: over/under voltage, overcurrent (maximum power) with switch
User switches/ buttons	Power supply ON-OFF. START/STOP buttons Min/Max engine speed. Power output activation/deactivation (for each output line) Power output activation forced (permanent output activation, also without feedback from aircraft - plug pins E-F). Alarm acknowledge and reset. Flashing light ON/OFF

WINTER KIT (ON REQUEST)

Fuel tank	Fuel tank preheating with internal coil for engine water circulator, supplied by 230V, 50Hz external power supply (during storage inside hangars)
Engine	Engine water preheating, supplied by 230V, 50Hz external power supply (during storage inside hangars) Engine air preheating, powered at 24V (during storage inside hangars)
Battery heaters	Battery heater, supplied by 230V, 50Hz external power supply (during storage inside hangars)